

MAGNALUX

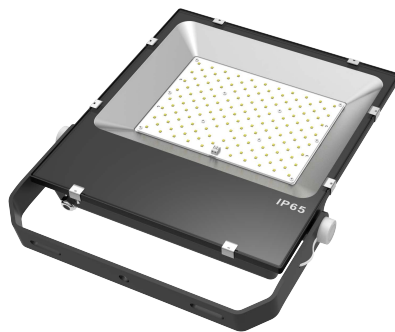

150W LED Flood Light



■ Specification

Model:	VPL-FL-150WAN-YYK
Color Range:	3000-5700K
Power:	150W
Light Source:	SMD3030
Housing:	AL + Glass
Operation Temperature:	-30°C ~ 60°C
Life Span:	50,000hours duty cycle
Voltage range:	AC100-277V/347V/480V
Frequiency:	50/60Hz
Beam angle:	120°
Luminous Efficacy:	120-130lm/W
Color index(CRI):	>80Ra
PF:	≥0.95
Certifications:	ETL cETL DLC
Warranty:	5 Years

■ Structure

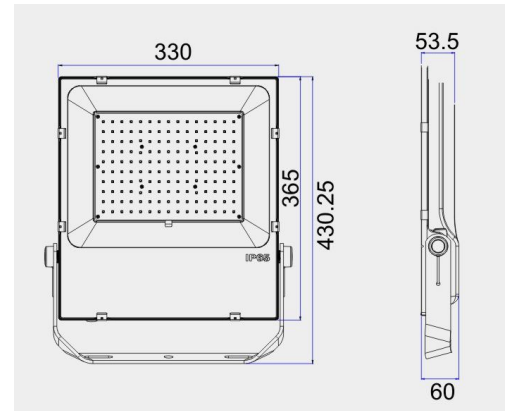

■ Features

1. Lumileds SMD3030 LED, high luminous flux, energy saving obviously.
2. Wide range voltage AC100-277V/347-480VAC.
3. Use the most efficiency integrated aluminum alloy, the completed lamp can work above 50000hrs
4. Aluminum alloy housing processed with anodization, solid in structure and withstand the corrosion.
5. Heat sink of different sizes from 10-200W, according to varied lighting requirement.
6. Protection rate: IP65.
7. Flexible position makes project angle can be adjusted within 216° .

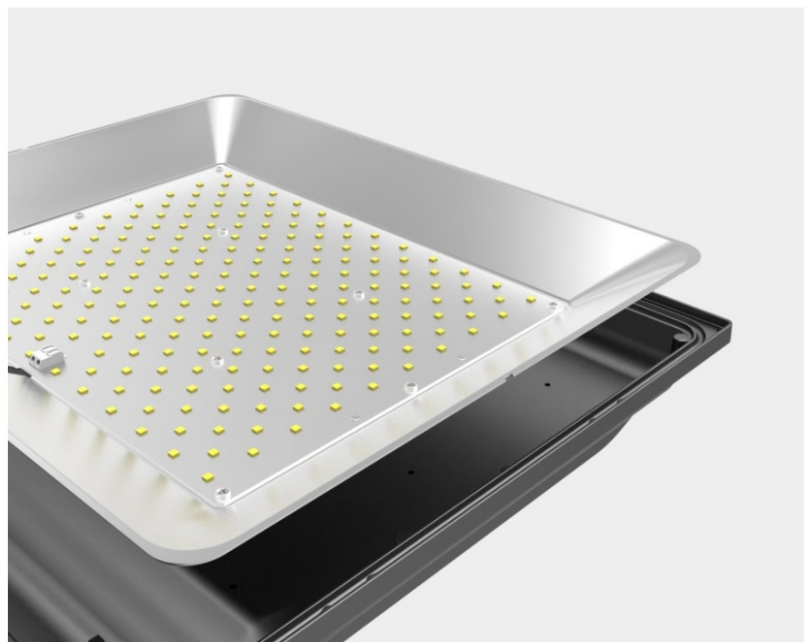
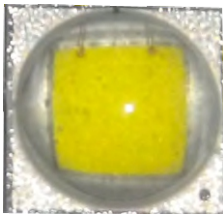

■ Distribution Curve

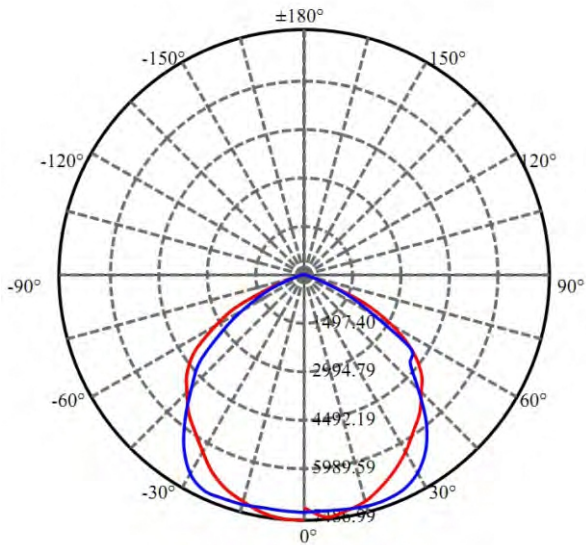

■ Illumination Map

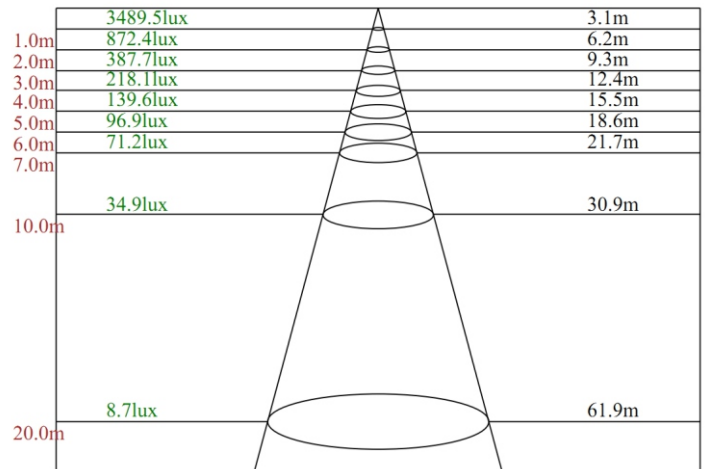

■ Installation

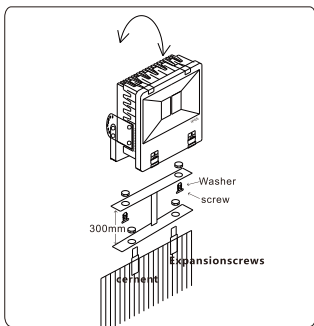

Install the lamp by the stand on the ground

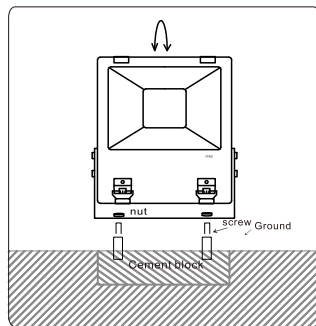

Install lamp directly

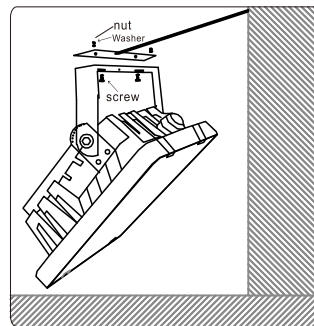

Hang the lamp by the stand

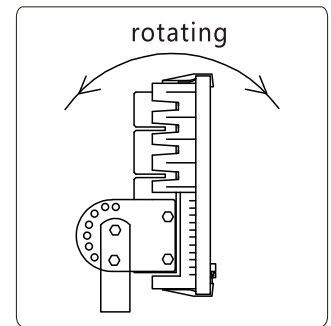

The angle of the lamp is adjustable

■ Packing

Net Weight: 5.9kg
 Gross Weight: 6.9kg (1pcs/ ctn)
 Carton Size: 520*440*140mm

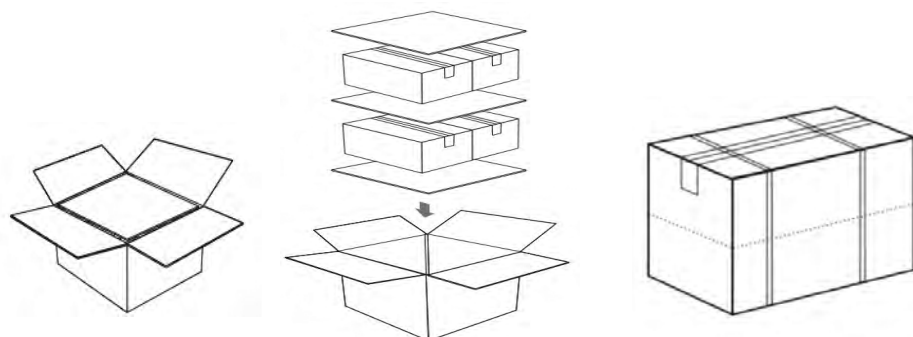

1

2

3